

SUSPENDED FLOOR

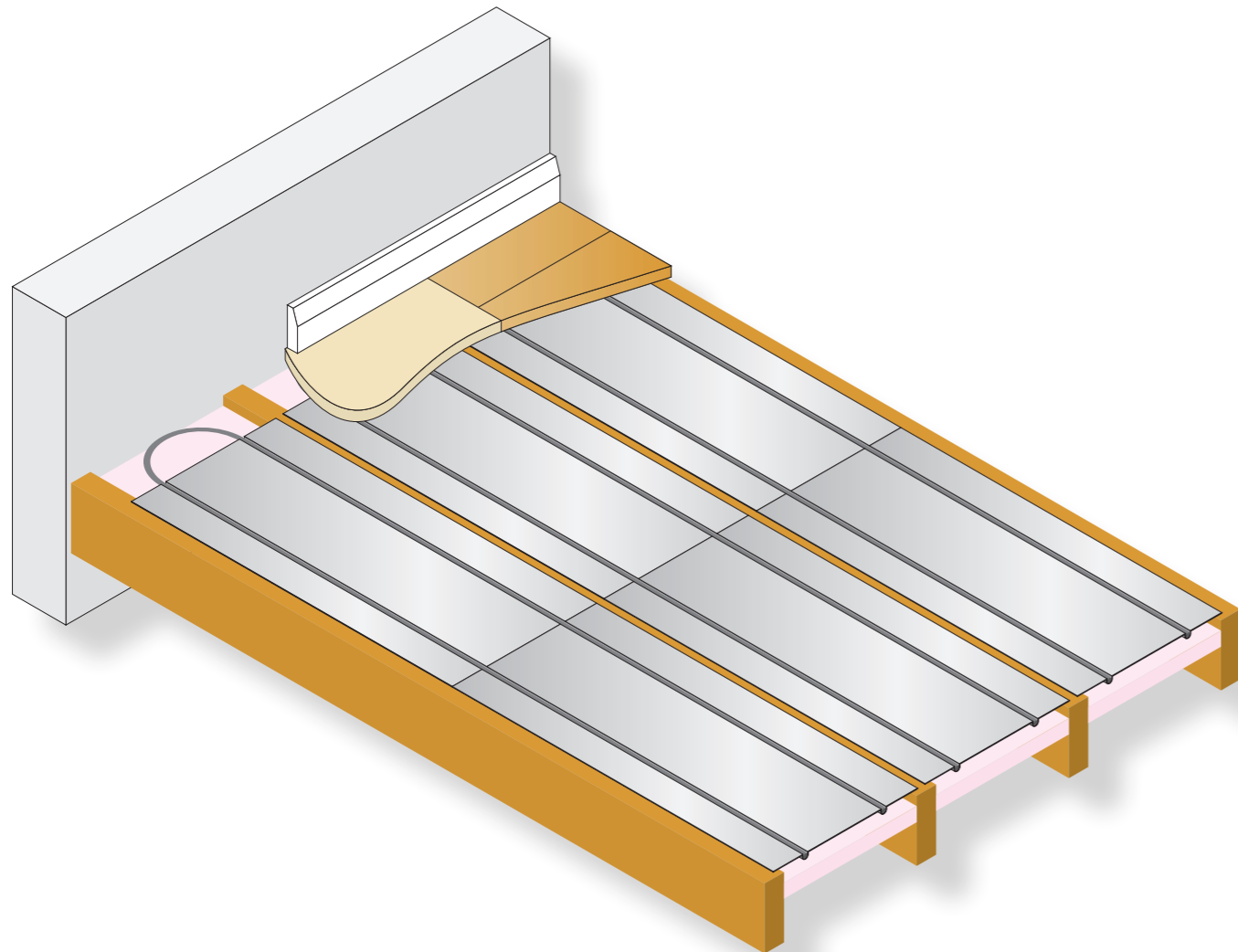

Designed for use in timber suspended or battened floors the Polypipe suspended floor system uses aluminium double heat spreader plates to transmit the heat evenly across the finished floor surface.

Suitable for joist widths of 300mm to 450mm the spreader plates are simply fixed to the joist using small nails or staples. The pipe is then run in to the preformed grooves of the panels which are designed to hold the pipe securely at 225mm average centers.

A layer of insulation below the panels will ensure that almost all of the heat generated passes up in to the room.

The Polypipe suspended floor system is also suitable for use with 'sprung' flooring systems as used in sports halls, etc.

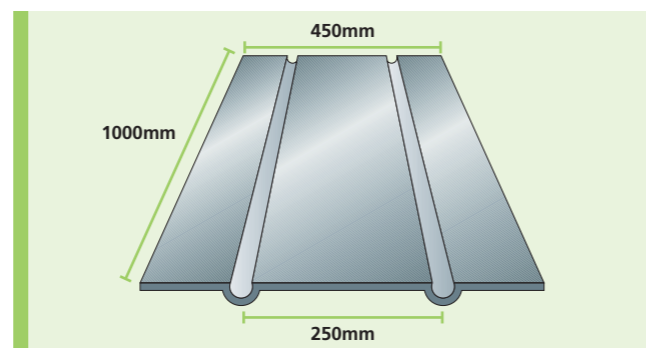

Pre-installation requirements

Key design and installation information

Maximum heat output	Approx. 70W/m ²
Recommended design flow temp	60°C
Maximum circuit length	80m (15mm pipe)
Maximum coverage per circuit double heat spreader plates (15mm)	17m ² at 225mm average centres

Material requirements (approx)

	Double heat spreader plates
Pipe	4.5m/m ²
Heat spreader plates	2 plates/m ²

Installation

Fitting Insulation

Step 1:

Before installing a suspended floor system it is necessary to insulate between the joists. Polypipe recommend that a rigid polystyrene or foam insulation material is used.

Fitting the spreader plates

Step 2:

The insulation layer should fit tightly between the joists directly below the spreader plate to ensure that the spreader plate is supported and therefore remains in contact with the underside of timber floor covering. This is necessary to eliminate any air gaps or draughts between the under floor heating system and the floor.

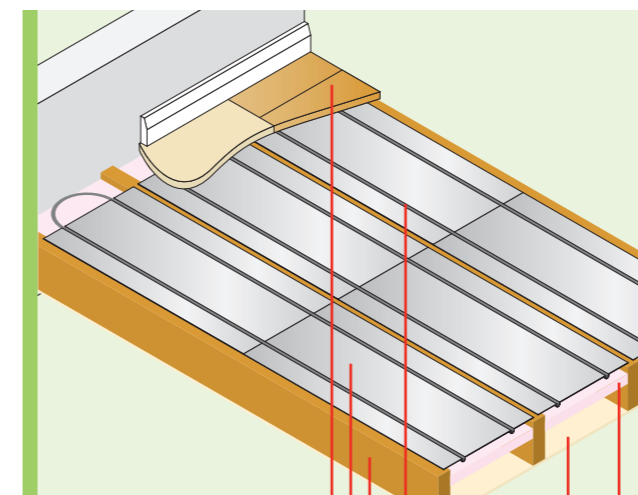

Any other services, such as drainage or electrical wiring, should be installed below the insulation layer.

The floor joists then need to be notched or drilled in accordance with Building Regulations. This facilitates the passage of the pipe between the joist gap to allow the entry and exit of the pipe to and from the room.

The spreader plates can then be fixed evenly across the joists and in accordance with your installation design.

Laying the pipe

Step 3:

Once the spreader plates have been fixed in place the pipe can be fitted in to the grooves in a meander pattern. It is recommended that the flow pipe from the manifold be taken to the furthest point of the room when installing the circuit as this ensures that sufficient heat is provided around the perimeters of the room.

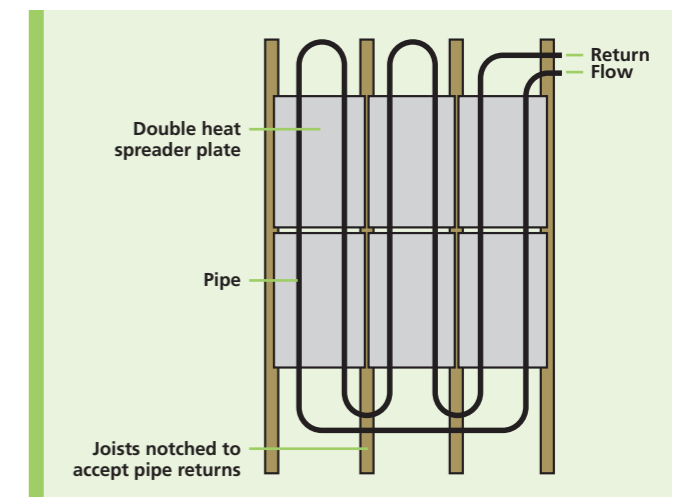

Care should be taken when installing the pipe to ensure the spreader plates are not pushed downwards and away from the underside of the timber finished floor covering as this could lead to potential underperformance of the system.

Testing

Step 4:

Once the pipe circuits have been installed and connected to the manifold the system should be pressure tested to 6 bar for a minimum of 1 hour before the timber floor covering is laid. It is recommended that the system remains under pressure whilst the flooring is laid.

Finishing

Laying a timber floor covering

Step 5:

It is strongly recommended that the timber floor covering is laid immediately after the under floor heating pipes have been installed and pressure tested to eliminate any risk of damage to the system by other trades.

Either traditional tongue & groove floorboards or 18mm/22mm chipboard can be fitted directly on top of the spreader plates. These can be fixed directly through the spreader plate down in to the joists below. It is important to indicate the position of pipework in areas where the additional fixing of items such as carpet grip rod or door threshold strips may be fitted at a future date.

Polypipe does not recommend the application of two layers of timber floor covering as this will severely reduce the heat output of the under floor heating system.

Correct application

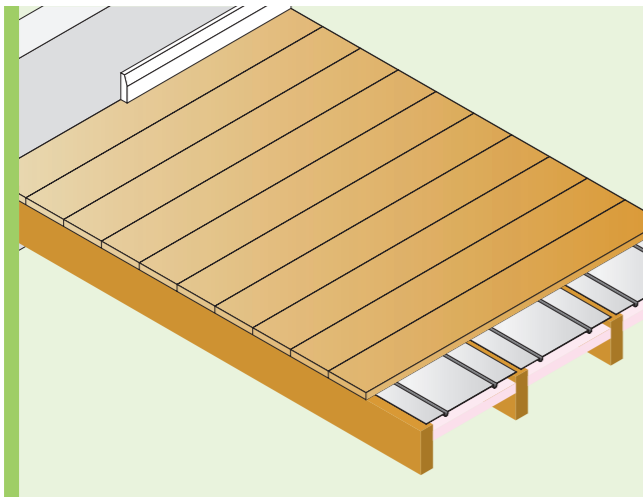

Incorrect application

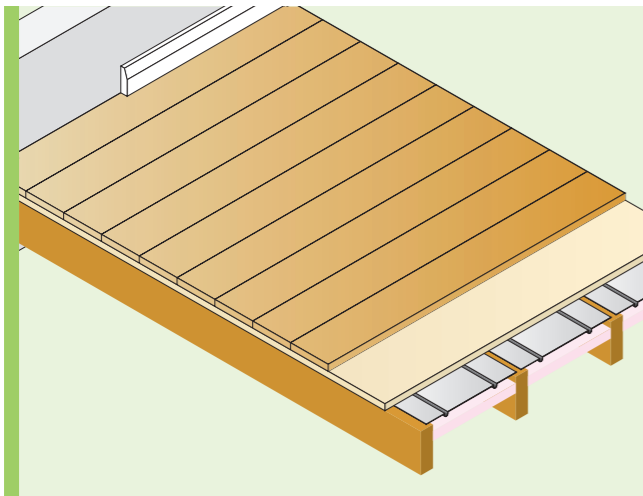

If a manufactured timber floor is to be used then it is recommended that this be of a suitable load bearing quality. (Please request advice from the specialist flooring supplier).

Battern systems

Used for spans greater than 450mm or less than 350mm. Where it is not possible or desirable to drill or notch the floor joists, and the floor height can be raised, spreader plates can be used.

Fitting insulation with a battern system

Step 1:

To prevent downward heat transmission, insulate between the voids in the joists with appropriate foam insulation.

Fitting the batterns

Step 2:

Lay 75mm x 25mm batterns across the existing joists at 450mm centres. Trim the ends of the battern back to the last joist at alternative ends.

Fitting the spreader plates

Step 3:

Lay spreader plates between the batterns and pin in position.

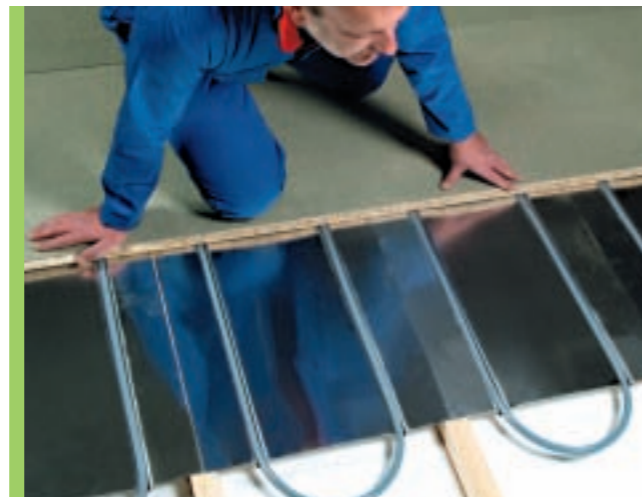

Laying the pipe

Step 4:

Lay pipe into the spreader plates in accordance with the installation instructions on the previous page, ensuring you follow the testing procedure.

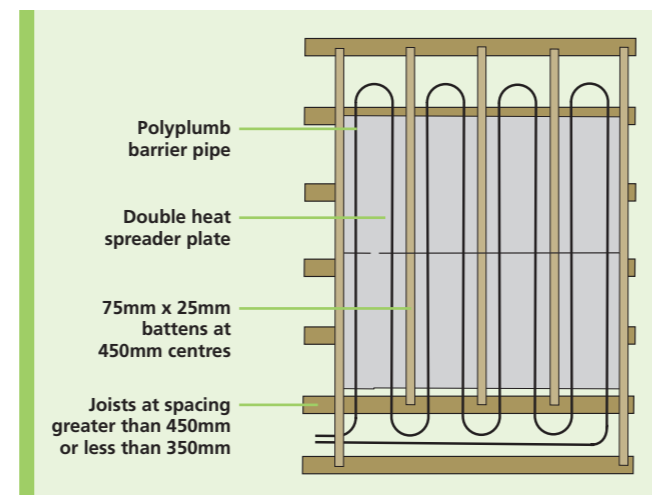

Pipe only systems

The use of heat spreader plates is recommended, as they assist the response time and heat dispersion. However, in some circumstances, simply laying pipe in an air void between foil faced reflective insulation and the underside of the floorboard will be adequate.

The space between the top of the insulation and the underside of the floor deck should be kept to a minimum (20mm) and care should be taken to ensure that the insulation is sealed at the edges and ends.

Pipe only applications are suitable in areas where the heating response is less important, e.g. bedrooms, and is not recommended in living spaces or over unheated spaces, e.g. rooms above garages.

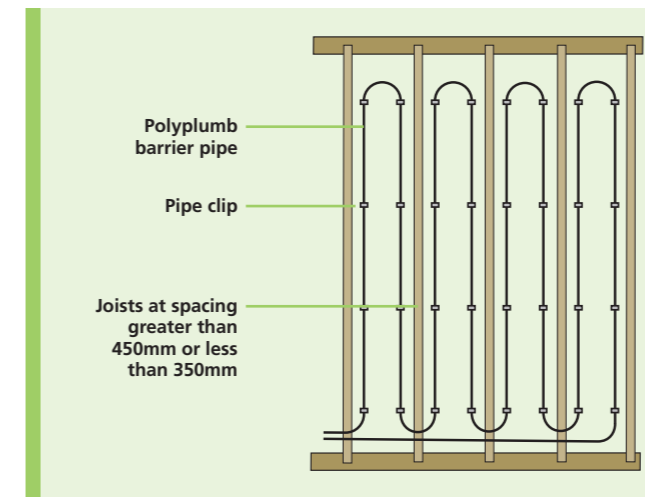

Enhancing pipe only systems

The effectiveness of pipe only systems can be enhanced by laying a weak (1:6) dry mix screed approximately 25mm thick between the joists.

In order to apply this, extra support may be required below the insulation. Although pipe only systems are designed to operate at 60°C flow temperature, the flow temperature may be reduced in these circumstances.

Before this system is considered it is suggested you consult a structural engineer to confirm its suitability.

